

# 317 SERIES

## Vertical Hold Down Clamps | Product Overview

### Features:

- Dual mounting surfaces
- Large bar opening angle
- Accommodates M8 or 5/16" spindle accessories

### Applications:

- Assembly & test
- Checking fixtures
- Light machining
- Woodworking

### Also Available:

See page MC-ACC-1 for accessories  
 817-U Pneumatic Toggle Clamp  
 (See page MC-PTC-19)  
 817-S Pneumatic Toggle Clamp  
 (See page MC-PTC-19)

**317-U**  
U-Bar



**317-S**  
Solid Bar



## Technical Information

Model	Max. Holding Capacity	Clamp Bar Opening (+10°)	Handle Opening (+10°)	Weight	Accessories (Supplied)		
					Bolt Retainer	Spindle Assembly	Flanged Washers
317-U	1670 N [375 lbf]	185°	60°	0,34kg [0.75lbs]	---	507208-M	507107
317-S	1780 N [400 lbf]				207105	---	---

## Holding Capacities

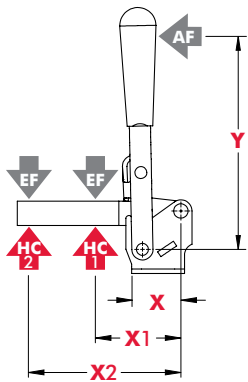

Model	X	X1	X2	Y	±HC1	±HC2	±EF(X1):AF	±EF(X2):AF
317-U	[1.57]	[2.00] 50,8	[3.75] 95,3	[4.00]	[375 lbf] 1670 N	[200lbf.] 900N	17:1	8:1
317-S	40,0	[2.50] 63,5	[5.00] 127,0	101,6	[400 lbf] 1780 N	[190lbf.] 850N	13:1	5:1

Dimensions shown "mm [inch]" ± HC = Holding Capacity, EF = Exerting Force, AF = Applied Force  
 See page MC-TEC-4 for additional information.

**317-U**  
U-Bar

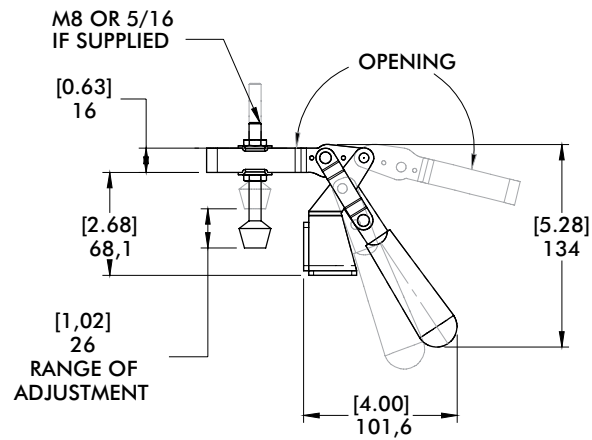
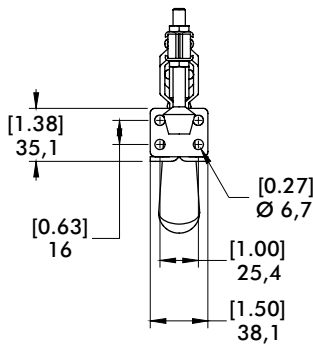
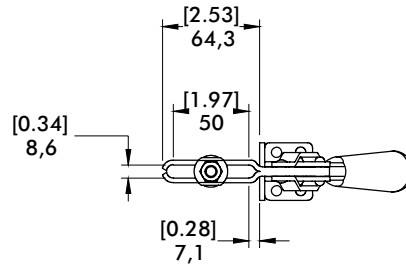

**317-S**  
Solid Bar

